

# CLEMENT SIDESTAR 2



## The side dump with Clement Innovation

The 39-foot SideStar2 is Clement's rugged, efficient new hauling system that discharges its load to either side of the trailer. SideStar2 is not just another side dump. It features all of the innovation and quality construction that made Clement "America's Leader."

### Innovation you'd expect from the industry leader SideStar's lightweight frame

- Tapered cross sections reduce both twist and frame bounce without adding payload-robbing weight.

### Super capacity, super strong body

- A 34-ft. (24-cu.yd capacity) parabolic body of 1/4-inch AR450 steel that's the hardest steel that can be provided. AR450 is 25 percent harder than AR400 and 138 percent harder than hi-tensile steel, which translates into increased trailer life for the Clement SideStar2.

AR450 is so hard, the SideStar2's body is tops in comparison to other manufacturers' bodies of AR400 and hi-tensile steel. SideStar handles the toughest of loads.

- As an option for the SideStar2, a body of 3/16-inch AR450 is available for increased payloads and material hauling.
- Smooth, rounded contours with chamfered corners and the widest side angle in the industry, move loads quicker with less sticking.
- Internal and external braces provide greater corner strength. Extra wide top rails combine with both end braces and three AR450 'I-Beam' body supports to form a super strong unit.
- Rounded top rails with flat surfaces plus deflectors on the front and back end panels make for a smooth tarp fit.



### SideStar2's outside body supports

Three AR450 'I-Beam' body supports that wrap the outside body to increase the integrity from rail-to-rail during the dumping cycle (a Clement exclusive) and eliminate the need for an internal divider.



### SideStar2's super strong top rail

One continuous high-yield steel top rail for superior support and clean lines.

**CLEMENT**  
*America's leader*  
IN DUMP TRAILERS

The Company reserves the right under its product improvement policy to change construction or design details and furnish equipment when so altered without reference to illustrations or specifications used herein.

# CLEMENT SIDESTAR 2

America's most exciting new hauling option!

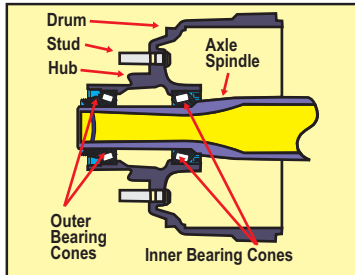

### Clement's firm foundation

Building a trailer is a lot like building a house. Put as much strength possible in the foundation and the structure will be strong and it will last! That's the Clement philosophy. With every trailer they start with **5/8-inch wall, 102-inch wide pro-par axles** with common inner and outer bearings. Then **pro-par's parallel spindles**, which greatly increase both bearing and axle life,

are added. **44,000 4-spring suspension** is another Clement standard, or if the buyer prefers, **50,000-lb. air ride** can be specified. **Hub-piloted wheels** are the final ingredient. Hub-piloted wheels have no inner nuts and all nuts have right-hand threads, plus there are only 10 nuts instead of the usual 20. This reduces both maintenance time and cost.

None of our competition has a stronger foundation than the one that's standard on every Clement trailer, and few even come close.



### Dependable cylinders

Twin, 5-inch, double-acting cylinders with a flow divider ensure that every load is properly dumped.

### The crowning touch

That deep lustrous shine on every Clement trailer is produced using the Sherwin-Williams "Genesis" paint system. So new, it's dubbed

"the paint of the future," Genesis is a low VOC, two-part urethane that's applied to the trailer after it's had a corrosion-reducing phosphate wash. The result is a tough, protective finish that has a lustrous, long lasting shine.

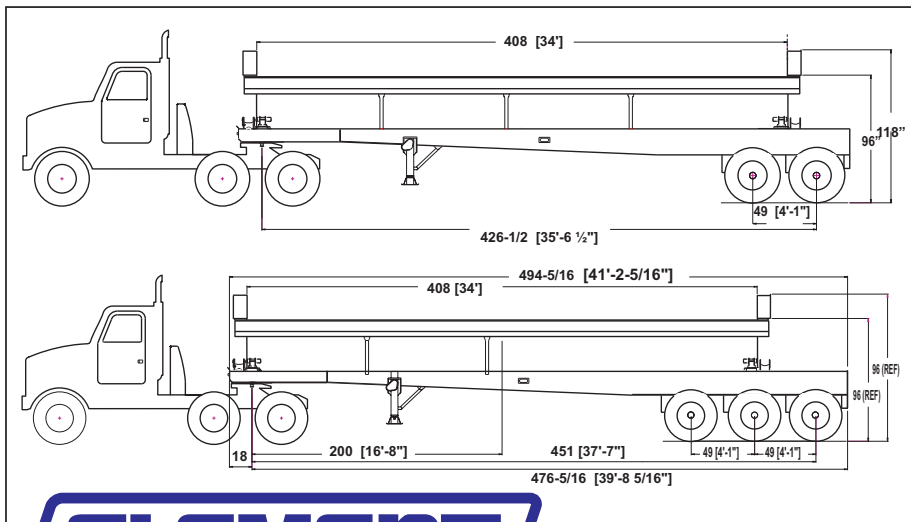

## Lightweight, High-strength Side Dump Trailer

### Specifications

Chassis length: 39 feet  
34-foot inside body length  
35'-8" overall trailer length  
40-inch sides for 24-cubic yard capacity

Easy access to hydraulic lines:

Hydraulic lines are routed through the frame's cross members for easy maintenance and accessibility.

Landing gear: Two-speed

Suspension: Hutch 4-spring (option: air ride)

Frame design includes structure for mounting push blocks or pintle hook

ABS braking system: Sealco/Rockwell/WABCO 4s2m

Cylinders: two (2) five-inch, double-acting dump cylinders with advanced seals and flow divide to cylinders\*

Wheels: (8) 8.25 x 24.5, hub-piloted

Tires: (8) Bridgestone 11R 24.5 radials

Fenders: Front and rear

\* optional: 6-inch hydraulic cylinders

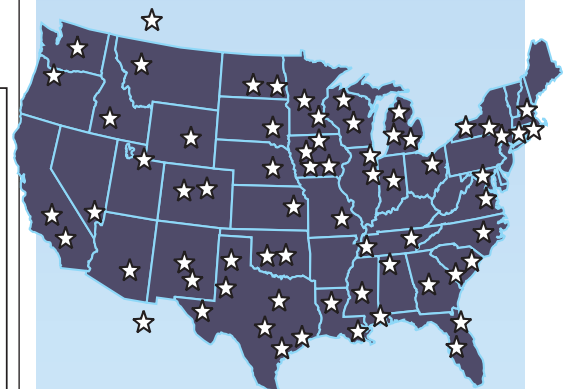

### Clement is just "down the road"

Clement's nationwide network of dealers means that Clement quality service and genuine Clement replacement parts are just "down the road" not across the country.

**CLEMENT**  
America's leader  
IN DUMP TRAILERS

P. O. Box 914, Minden, LA 71058-0914

1-800-562-5948, FAX: 318-377-8426

E-Mail: [sales@clementind.com](mailto:sales@clementind.com), Web site: <http://www.clementind.com>

For more information, call your local Clement Distributor: